

HP-3820

BANCHI DI VETRATURA
GLAZING BENCHES

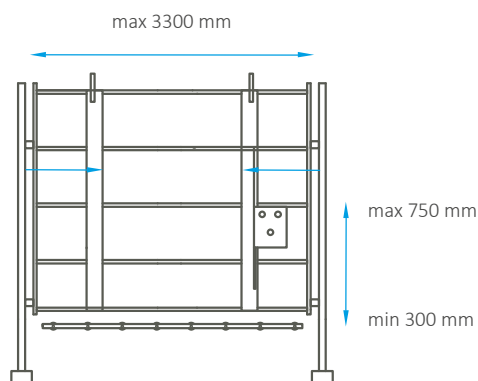

guarda il video
watch the video



1. Il modello **HP3820** rispetto al modello F3820, implementa la possibilità di alzarsi od abbassarsi fino a **45 cm** a seconda delle proprie esigenze operative, permettendo di lavorare serramenti di dimensioni modeste in posizione ottimale;
2. Le spalle di bloccaggio laterali sono a scomparsa, così da facilitare la movimentazione del quadrato sul banco;
3. L'altezza iniziale della superficie di appoggio al suolo viene pre-regolata secondo le esigenze del cliente in fase di collaudo.



1. The model **HP3820** compared to F3820 model, implements the possibility of rising or lowering up to **45 cm** depending on your operating needs, allowing you to work small size windows in an optimal position;
2. The lateral clamping units are hidden, so as to facilitate the movement of the square on the bench;
3. The initial height of the ground support surface is pre-adjusted according to the customer's needs during the testing phase.

CENTRI LAVORAZIONE PER ASSEMBLAGGIO PERSIANE E SKURI IN PVC
PROCESSING UNIT FOR UPVC SHUTTERS

GLAZING BENCHES

BANCHI DI VETRATURA

MISURE E CARATTERISTICHE TECNICHE MEASUREMENTS AND TECHNICAL CHARACTERISTICS

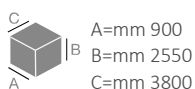

A=mm 900
B=mm 2550
C=mm 3800



Kg 420



A = mm 3300 max



7 bar -
50 L/cicle

